

SCHEDA D'IDENTIFICAZIONE

IDENTIFICATION SHEET

FICHE D'IDENTIFICATION

La presente scheda di identificazione riproduce descrizioni, illustrazioni e dimensioni del motore ROK DVS per l'utilizzo nella **SUPER ROK CUP** riconosciuta dall'ACI SPORT.

This Identification Sheet reproduces descriptions, illustrations and dimensions of the ROK DVS engine to be used in the **SUPER ROK CUP** recognised by the ACI SPORT.

La présente Fiche d'Identification reproduit descriptions, illustrations et dimensions du moteur ROK DVS utilisé dans le **SUPER ROK CUP** reconnue par la ACI SPORT.



ATTENTION

TUTTI LE PARTI DEL MOTORE DEVONO ESSERE ORIGINALI VORTEX ROK.

Né il motore né gli accessori possono essere in alcun modo modificati.

Per modifica si intende qualsiasi cambiamento di forma, contenuto o funzione, che rappresenti una condizione di differenza da quanto originariamente costruito, ivi inclusa l'aggiunta e/o l'asportazione di materiale

Tutte le misure dimensionali nei disegni tecnici si intendono in mm.

ALL THE ENGINE PARTS MUST BE ORIGINAL BY VORTEX ROK.

Neither engines nor accessories can be modified. By this we mean any shape, content or function changes which may differ from what previously conceived. Furthermore this includes any addition and /or removal of material.

All dimensional measures in the technical drawings are in mm.

TOUTES LES PARTS DU MOTEUR DOIVENT ETRE ORIGINALES VORTEX ROK.

Ni le moteurs ni les accessoires peuvent être modifiés. Tout changement dans la forme, le contenu ou le fonctionnement qui puisse apporter des modifications au projet initial est interdit. Ci-inclus aussi l'addition et/ou l'enlèvement de matériaux.

Toutes les mesures dimensionnelles dans les dessins techniques sont en mm.

ALESAGGIO ORIGINALE	ORIGINAL BORE	ALESAGE D'ORIGINE	54.10 mm
ALESAGGIO MASSIMO	MAX ALLOWED BORE	ALESAGE MAXIMUM	54.28 mm
CORSA	STROKE	COURSE	54±0.2 mm
CILINDRATA ORIGINALE	ORIGINAL DISPLACEMENT	CAPACITE' D'ORIGINE	124.176 cm ³
INTERASSE BIELLA	CONROD INTERAXLE	ENTRAXE DE LA BIELLE	102±0.2 mm

**SVILUPPO DEL CILINDRO e DISTRIBUZIONE
CYLINDER DEVELOPEMENT and DISTRIBUTION
DEVELOPEMENT DU CYLINDRE ET DISTRIBUTION**

SCARICO	EXHAUST	ECHAPPEMENT	193° MAX
BOOSTER	BOOSTER	BOOSTER	177° MAX
TRAVASI PRINCIPALI	MAIN TRANSFERS	TRANSFERES PRINCIPALS	128° MAX
TRAVASI SECONDARI	SECONDARY TRANSFERS	TRANSFERES SECONDAIRES	124° MAX

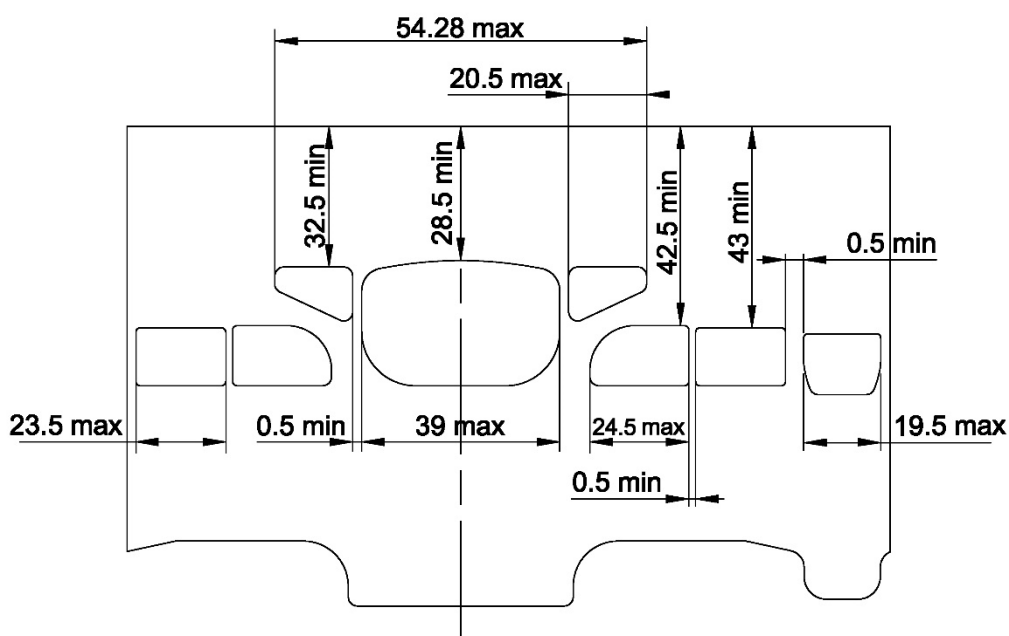

Controllo della distribuzione come descritto nel Regolamento Tecnico Rok Cup 2019, art. 6.1.2
 Check of the Distribution as described in the Rok Cup 2019 Technical Regulations, art. 6.1.2
 Contrôle de la distribution tel que décrit dans le règlement technique Rok Cup 2019 art. 6.1.2



ATTENTION	TUTTI LE PARTI DEL MOTORE DEVONO ESSERE ORIGINALI VORTEX ROK.
	Né il motore né gli accessori possono essere in alcun modo modificati.
	Per modifica si intende qualsiasi cambiamento di forma, contenuto o funzione, che rappresenti una condizione di differenza da quanto originariamente costruito, ivi inclusa l'aggiunta e/o l'asportazione di materiale
	Tutte le misure dimensionali nei disegni tecnici si intendono in mm.
	ALL THE ENGINE PARTS MUST BE ORIGINAL BY VORTEX ROK.
Neither engines nor accessories can be modified. By this we mean any shape, content or function changes which may differ from what previously conceived. Furthermore this includes any addition and /or removal of material.	
All dimensional measures in the technical drawings are in mm.	
TOUTES LES PARTS DU MOTEUR DOIVENT ETRE ORIGINALES VORTEX ROK.	
Ni le moteurs ni les accessoires peuvent être modifiés. Tout changement dans la forme, le contenu ou le fonctionnement qui puisse apporter des modifications au projet initial est interdit. Ci-inclus aussi l'addition et/ou l'enlèvement de matériaux.	
Toutes les mesures dimensionnelles dans les dessins techniques sont en mm.	

DESCRIZIONE : CUILINDRO CON CANNA IN GHISA
 DESCRIPTION : CYLINDER WITH CAST IRON LINER
 DESCRIPTION : CYLINDRE AVEC CHEMISE EN FONTE

BASE CILINDRO
 CYLINDER BASE
 PIED DU CYLINDRE

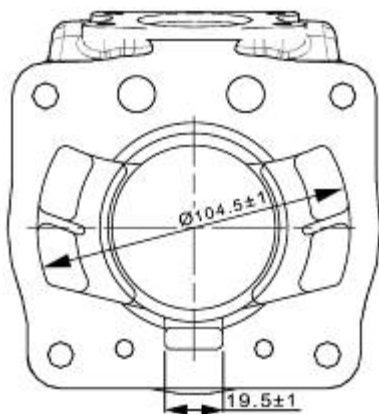

SEZIONE DEL CILINDRO
 CYLINDER SECTION
 COUPE PAR SECTION DU CYLINDRE

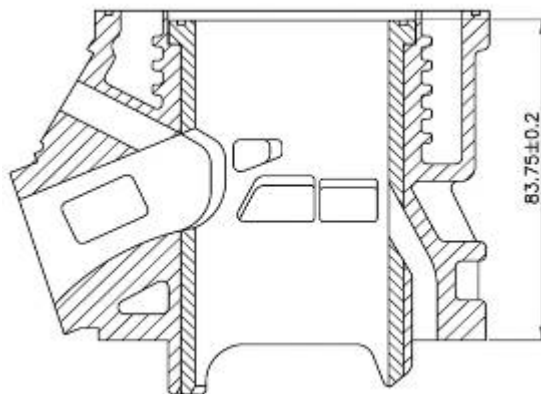

BASE CILINDRO
 CYLINDER BASE
 PIED DU CYLINDRE



CONDOTTO DI SCARICO
 EXHAUST DUCT
 CONDUITE D'ECHAPPEMENT



COLLETORE DI SCARICO EXHAUST MANIFOLD
 COLLECTEUR ECHAPPEMENT

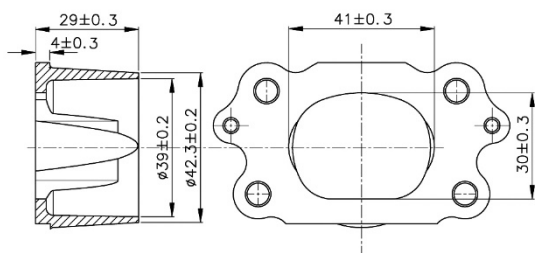

DISTANZIALE SCARICO - EXHAUST
 SPACER

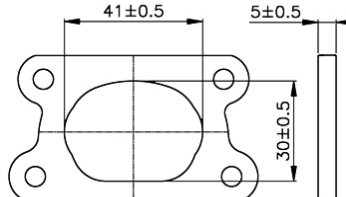

OPTIONAL: MAX N° 4

GUARNIZIONE SCARICO EXHAUST GASKET

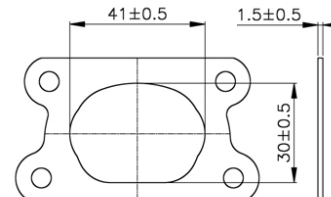

OPTIONAL: MAX N° 5

ATTENTION

TUTTI LE PARTI DEL MOTORE DEVONO ESSERE ORIGINALI VORTEX ROK.

Né il motore né gli accessori possono essere in alcun modo modificati.

Per modifica si intende qualsiasi cambiamento di forma, contenuto o funzione, che rappresenti una condizione di differenza da quanto originariamente costruito, ivi inclusa l'aggiunta e/o l'asportazione di materiale

Tutte le misure dimensionali nei disegni tecnici si intendono in mm.

ALL THE ENGINE PARTS MUST BE ORIGINAL BY VORTEX ROK.

Neither engines nor accessories can be modified. By this we mean any shape, content or function changes which may differ from what previously conceived. Furthermore this includes any addition and /or removal of material.

All dimensional measures in the technical drawings are in mm.

TOUTES LES PARTS DU MOTEUR DOIVENT ETRE ORIGINALES VORTEX ROK.

Ni le moteurs ni les accessoires peuvent être modifiés. Tout changement dans la forme, le contenu ou le fonctionnement qui puisse apporter des modifications au projet initial est interdit. Ci-inclus aussi l'addition et/ou l'enlèvement de matériaux.

Toutes les mesures dimensionnelles dans les dessins techniques sont en mm.

**TESTA E CAMERA DI COMBUSTIONE
CYLINDERHEAD AND COMBUSTION CHAMBER
CULASSE ET CHAMBRE DE COMBUSTION**

Volume della Camera di Combustione, misurato come descritto nel Reg.Tecnico ROK CUP 2019, art. 6.1 e 6.1.1
Combustion Chamber Volume: measured as described in the Rok Cup Technical Regulation 2019, art. 6.1 e 6.1.1
Volume de la Chambre de Combustion: mesurée comme décrit dans la règle technique ROK CUP 2019 art. 6.1 et 6.1.1

SQUISH THICKNESS – SQUISH - EPESSEUR DE SQUISH : 0.80 mm MIN

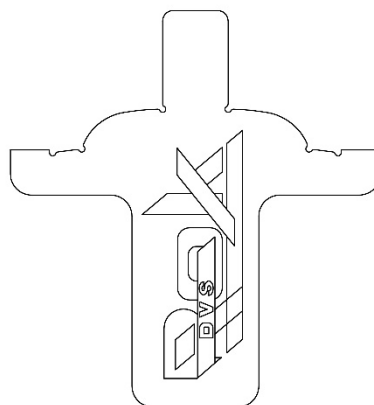
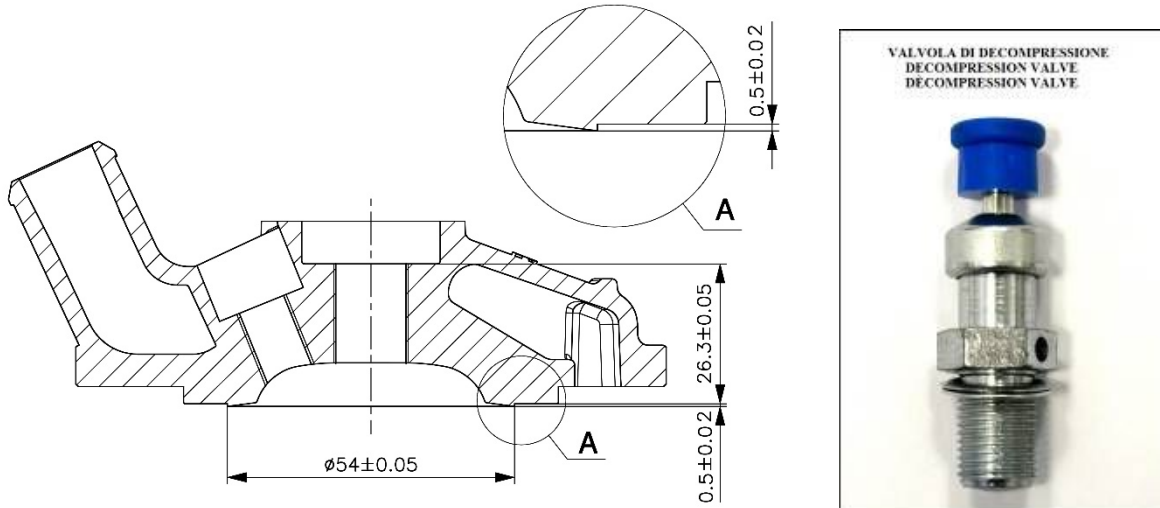

**DIMA CONTROLLO PROFILO CAMERA DI COMBUSTIONE TIPO B
TEMPLATE FOR CHECKING THE COMBUSTION CHAMBER PROFILE TYPE B
GABARIT POUR LA VERIFICATION DU PROFIL DE LA CHAMBRE DE COMBUSTION TYPE B**

ATTENTION

TUTTI LE PARTI DEL MOTORE DEVONO ESSERE ORIGINALI VORTEX ROK.

Né il motore né gli accessori possono essere in alcun modo modificati.

Per modifica si intende qualsiasi cambiamento di forma, contenuto o funzione, che rappresenti una condizione di differenza da quanto originariamente costruito, ivi inclusa l'aggiunta e/o l'asportazione di materiale

Tutte le misure dimensionali nei disegni tecnici si intendono in mm.

ALL THE ENGINE PARTS MUST BE ORIGINAL BY VORTEX ROK.

Neither engines nor accessories can be modified. By this we mean any shape, content or function changes which may differ from what previously conceived. Furthermore this includes any addition and /or removal of material.

All dimensional measures in the technical drawings are in mm.

TOUTES LES PARTS DU MOTEUR DOIVENT ETRE ORIGINALES VORTEX ROK.

Ni le moteurs ni les accessoires peuvent être modifiés. Tout changement dans la forme, le contenu ou le fonctionnement qui puisse apporter des modifications au projet initial est interdit. Ci-inclus aussi l'addition et/ou l'enlèvement de matériaux.

Toutes les mesures dimensionnelles dans les dessins techniques sont en mm.

ALBERO MOTORE – BIELLA – ASSE DI ACCOPPIAMENTO
CRANKSHAFT – CONROD - CRANKSHAFT COUPLING AXIS / VILEBREQUIN – BIELLE – AXE DE COUPLAGE VILEBREQUIN

Biella – Conrod – Bielle

Asse d'accoppiamento
 Crankshaft Crankpin
 Axe de Villebrequin

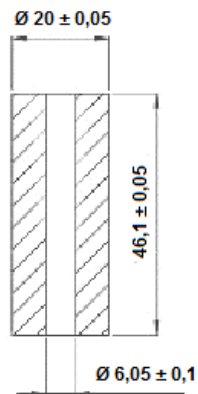

Peso – Weight – Poids
103gr±1gr

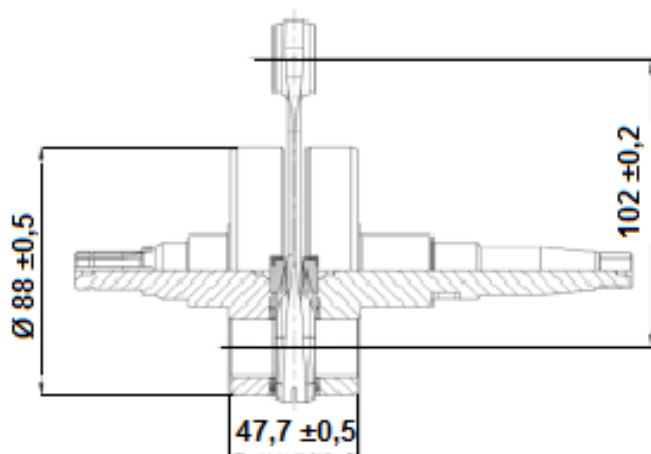

Peso completo / Complete Weight / Poids Complete
1976g ± 20g

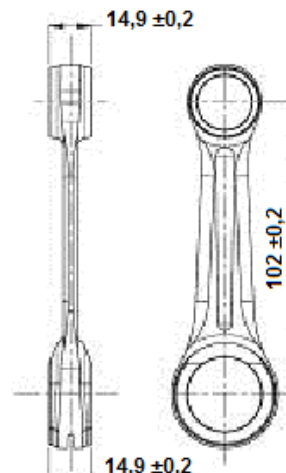

Peso – Weight – Poids
124gr ± 5gr

FOTO DELLA BIELLA
 PICTURES OF CONROD
 PHOTO DE LA BIELLE

FOTO DELL'ALBERO MOTORE
 PICTURE OF CRANKSHAFT
 PHOTOS DE VILEBREQUIN

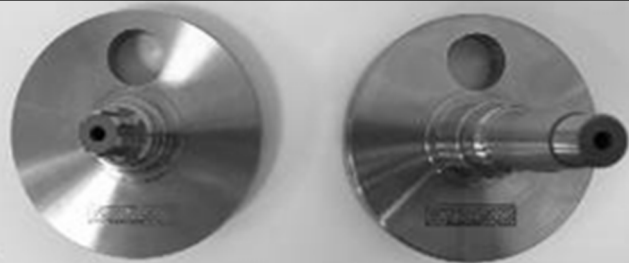

ATTENTION

TUTTI LE PARTI DEL MOTORE DEVONO ESSERE ORIGINALI VORTEX ROK.

Né il motore né gli accessori possono essere in alcun modo modificati.
 Per modifica si intende qualsiasi cambiamento di forma, contenuto o funzione, che rappresenti una condizione di differenza da quanto originariamente costruito, ivi inclusa l'aggiunta e/o l'asportazione di materiale
 Tutte le misure dimensionali nei disegni tecnici si intendono in mm.

ALL THE ENGINE PARTS MUST BE ORIGINAL BY VORTEX ROK.

Neither engines nor accessories can be modified. By this we mean any shape, content or function changes which may differ from what previously conceived. Furthermore this includes any addition and /or removal of material.
 All dimensional measures in the technical drawings are in mm.

TOUTES LES PARTS DU MOTEUR DOIVENT ETRE ORIGINALES VORTEX ROK.

Ni le moteurs ni les accessoires peuvent être modifiés. Tout changement dans la forme, le contenu ou le fonctionnement qui puisse apporter des modifications au projet initial est interdit. Ci-inclus aussi l'addition et/ou l'enlèvement de matériaux.
 Toutes les mesures dimensionnelles dans les dessins techniques sont en mm.

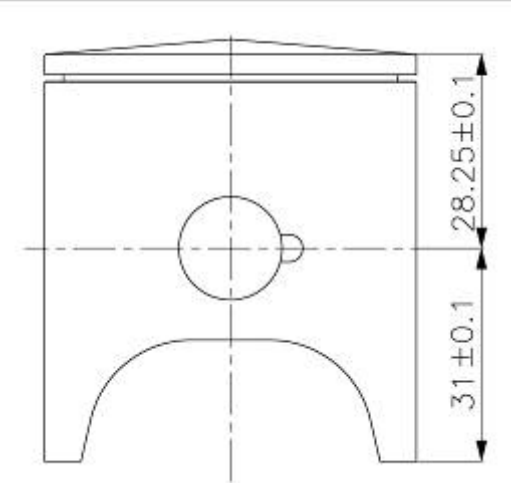
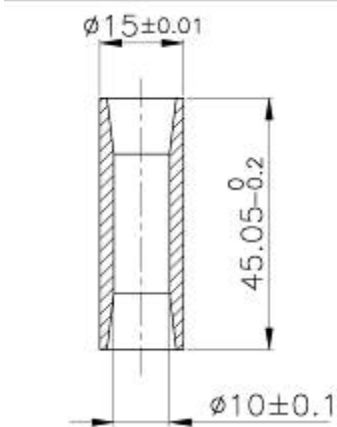
PISTONE TIPO B PISTON TYPE B PISTON TYPE B	SPINOTTO PISTONE PISTON PIN AXE DE PISTON
 <p style="text-align: center;"> <u>PESO</u> <u>WEIGHT</u> <u>POID</u> </p> <p style="text-align: center;">118gr/ ±5gr</p>	 <p style="text-align: center;"> <u>PESO</u> <u>WEIGHT</u> <u>POID</u> </p> <p style="text-align: center;">30gr min</p>

**Obbligatorio avere il pistone marchiato VORTEX in fusione come da figure
 mandatory to have the VORTEX brand cast piston as shown in the pictures
 Obligatoire d' avoir le piston en fonte marque VORTEX comme sur les figures**



ATTENTION	<p>TUTTI LE PARTI DEL MOTORE DEVONO ESSERE ORIGINALI VORTEX ROK. Né il motore né gli accessori possono essere in alcun modo modificati. Per modifica si intende qualsiasi cambiamento di forma, contenuto o funzione, che rappresenti una condizione di differenza da quanto originariamente costruito, ivi inclusa l'aggiunta e/o l'asportazione di materiale Tutte le misure dimensionali nei disegni tecnici si intendono in mm. ALL THE ENGINE PARTS MUST BE ORIGINAL BY VORTEX ROK. Neither engines nor accessories can be modified. By this we mean any shape, content or function changes which may differ from what previously conceived. Furthermore this includes any addition and /or removal of material. All dimensional measures in the technical drawings are in mm. TOUTES LES PARTS DU MOTEUR DOIVENT ETRE ORIGINALES VORTEX ROK. Ni le moteurs ni les accessoires peuvent être modifiés. Tout changement dans la forme, le contenu ou le fonctionnement qui puisse apporter des modifications au projet initial est interdit. Ci-inclus aussi l'addition et/ou l'enlèvement de matériaux. Toutes les mesures dimensionnelles dans les dessins techniques sont en mm.</p>
------------------	----------------------------------------------------------------------------------------------------------------------------------------------------------------------------------------------------------------------------------------------------------------------------------------------------------------------------------------------------------------------------------------------------------------------------------------------------------------------------------------------------------------------------------------------------------------------------------------------------------------------------------------------------------------------------------------------------------------------------------------------------------------------------------------------------------------------------------------------------------------------------------------------------------------------------------------------------------------------------------------------------------------------------------------------------------------------------------------------------------------------------------------------------------------------------------------------------------------------------------------------------------------------------------------------------------------------

CONTRALBERO D'EQUILIBRATURA
BALANCER SHAFT
ARBRE D'EQUILIBRAGE

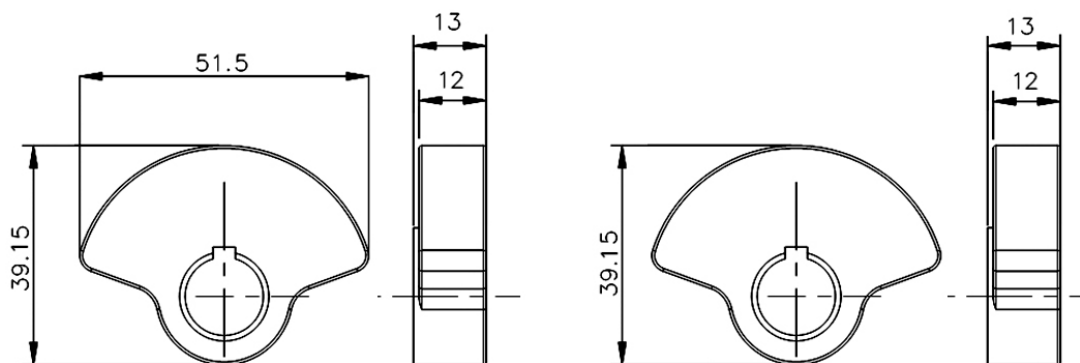

TOLLERANZE GENERALI GENERAL TOLERANCE TOLERANCES GENERALES ± 0.1 mm

PESO - WEIGHT - POID

212gr / ± 10 gr

FOTO DEL CONTRALBERO D'EQUILIBRATURA
PHOTO DE L'ARBRE D'ÉQUILIBRAGE
PHOTO OF THE BALANCE SHAFT



ATTENTION

TUTTI LE PARTI DEL MOTORE DEVONO ESSERE ORIGINALI VORTEX ROK.

Né il motore né gli accessori possono essere in alcun modo modificati.

Per modifica si intende qualsiasi cambiamento di forma, contenuto o funzione, che rappresenti una condizione di differenza da quanto originariamente costruito, ivi inclusa l'aggiunta e/o l'asportazione di materiale

Tutte le misure dimensionali nei disegni tecnici si intendono in mm.

ALL THE ENGINE PARTS MUST BE ORIGINAL BY VORTEX ROK.

Neither engines nor accessories can be modified. By this we mean any shape, content or function changes which may differ from what previously conceived. Furthermore this includes any addition and /or removal of material.

All dimensional measures in the technical drawings are in mm.

TOUTES LES PARTS DU MOTEUR DOIVENT ETRE ORIGINALES VORTEX ROK.

Ni le moteurs ni les accessoires peuvent être modifiés. Tout changement dans la forme, le contenu ou le fonctionnement qui puisse apporter des modifications au projet initial est interdit. Ci-inclus aussi l'addition et/ou l'enlèvement de matériaux.

Toutes les mesures dimensionnelles dans les dessins techniques sont en mm.

VISTA INTERNA DEL CARTER
INTERIOR VIEW OF THE CRANKCASE
VUE DE LA PARTIE INTERIEURE DU CARTER

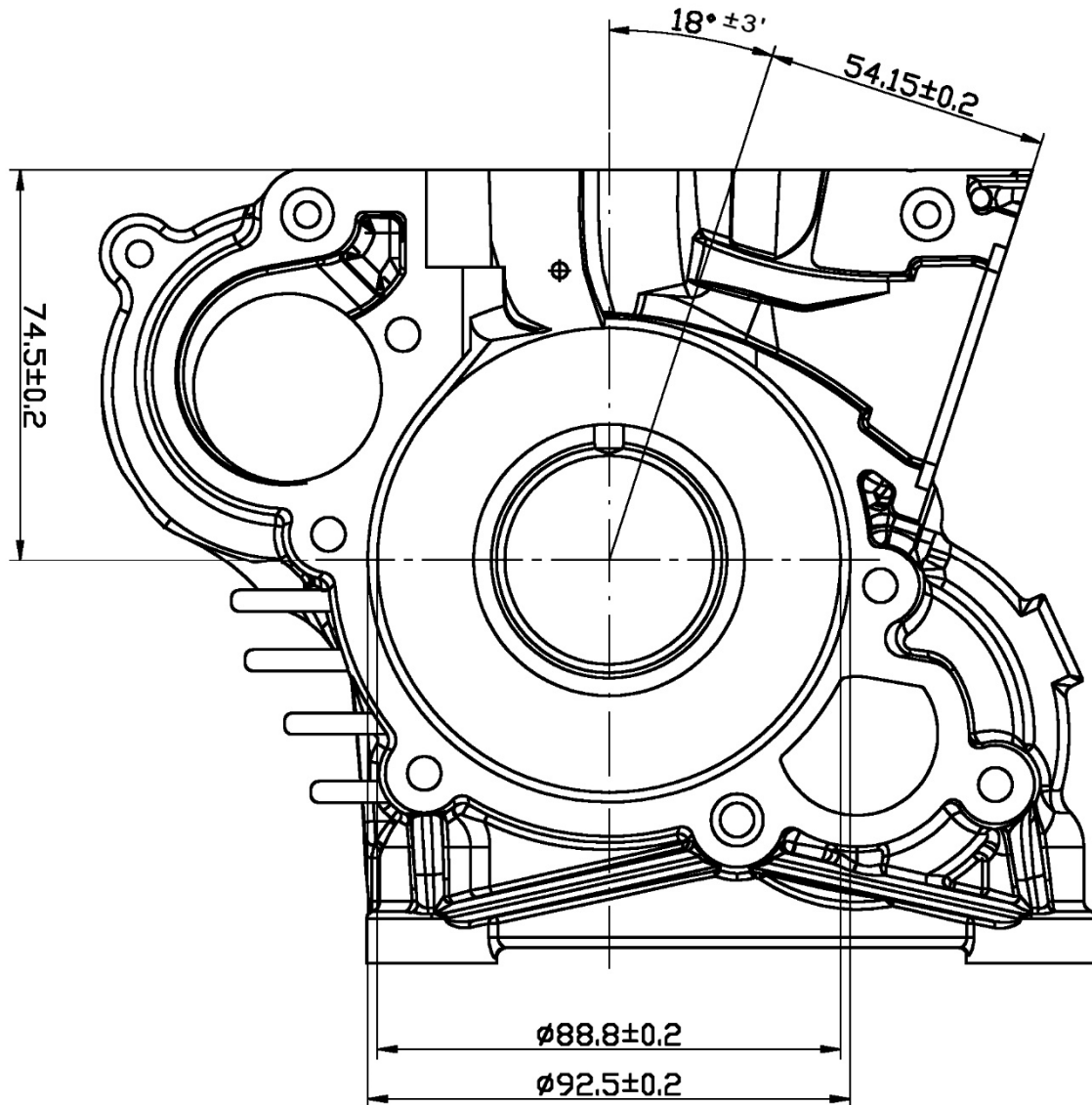

ATTENTION

TUTTI LE PARTI DEL MOTORE DEVONO ESSERE ORIGINALI VORTEX ROK.

Né il motore né gli accessori possono essere in alcun modo modificati.

Per modifica si intende qualsiasi cambiamento di forma, contenuto o funzione, che rappresenti una condizione di differenza da quanto originariamente costruito, ivi inclusa l'aggiunta e/o l'asportazione di materiale

Tutte le misure dimensionali nei disegni tecnici si intendono in mm.

ALL THE ENGINE PARTS MUST BE ORIGINAL BY VORTEX ROK.

Neither engines nor accessories can be modified. By this we mean any shape, content or function changes which may differ from what previously conceived. Furthermore this includes any addition and /or removal of material.

All dimensional measures in the technical drawings are in mm.

TOUTES LES PARTS DU MOTEUR DOIVENT ETRE ORIGINALES VORTEX ROK.

Ni le moteurs ni les accessoires peuvent être modifiés. Tout changement dans la forme, le contenu ou le fonctionnement qui puisse apporter des modifications au projet initial est interdit. Ci-inclus aussi l'addition et/ou l'enlèvement de matériaux.

Toutes les mesures dimensionnelles dans les dessins techniques sont en mm.

PACCO LAMELLARE E CONVOGLIATORE
REED BLOCK AND CONVEYOR
PYRAMIDE CLAPETS ET CONVOYEUR

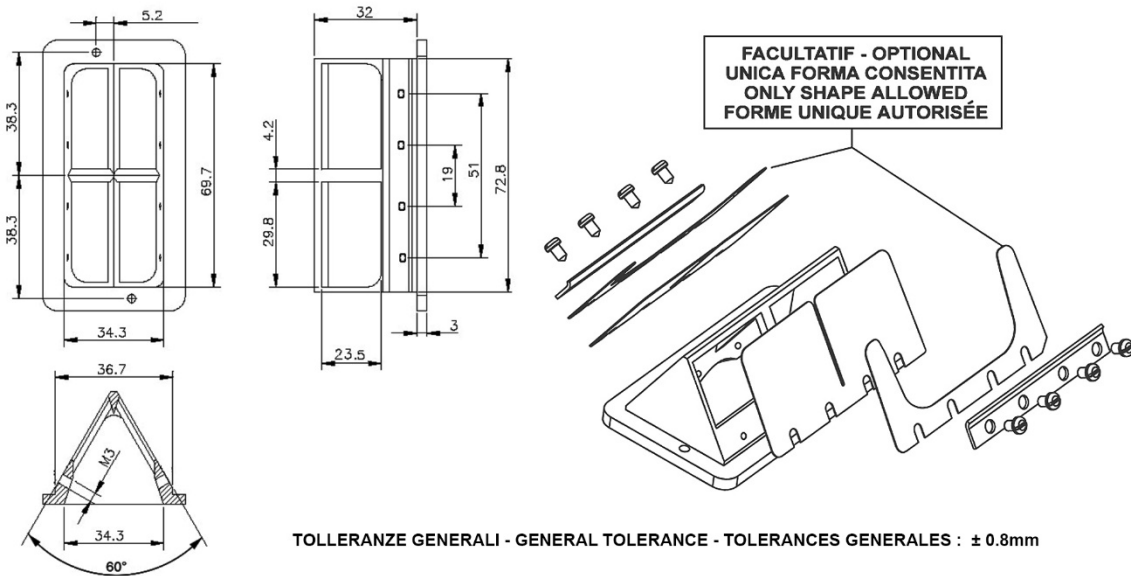

E' POSSIBILE AGGIUNGERE UN SOLO RINFORZO (BALESTRINO) SULLE LAMELLE
IT'S ALLOWED TO ADD ONLY ONE REINFORCEMENT (STOPPER) ON THE PETALS
EST POSSIBLE AJOUTER UN RENFORT (RESSORT A LAMES) SUR LES CLAPETS

GUARNIZIONE
GASKET
JOINT

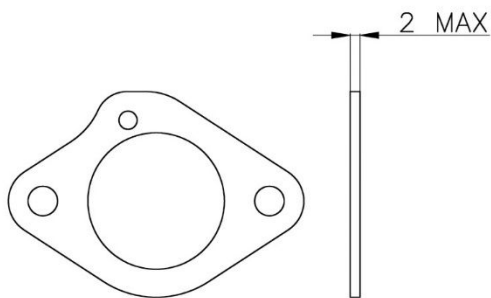

SPESSORE MAX GUARNIZIONE 2 MM
MAX GASKET THICKNESS 2 MM
JOINT D'EPAISSEUR MAXIMALE 2 MM

CONVOGLIATORE
REED VALVE COVER
COUVERCLE DE LA BOÎTE À CLAPETS

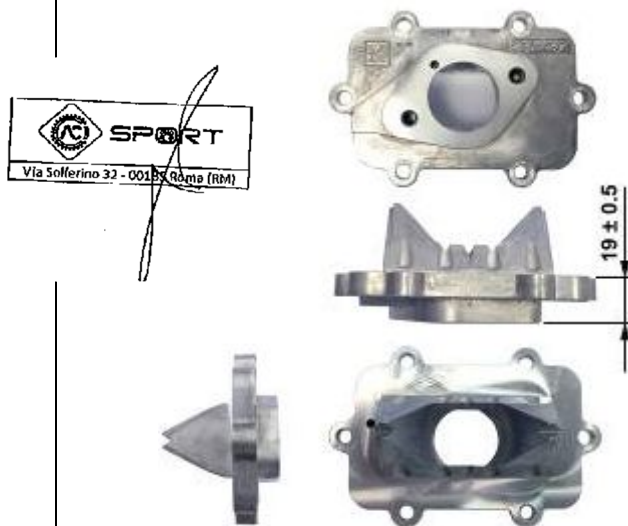

ATTENTION

TUTTI LE PARTI DEL MOTORE DEVONO ESSERE ORIGINALI VORTEX ROK.

Né il motore né gli accessori possono essere in alcun modo modificati.

Per modifica si intende qualsiasi cambiamento di forma, contenuto o funzione, che rappresenti una condizione di differenza da quanto originariamente costruito, ivi inclusa l'aggiunta e/o l'asportazione di materiale

Tutte le misure dimensionali nei disegni tecnici si intendono in mm.

ALL THE ENGINE PARTS MUST BE ORIGINAL BY VORTEX ROK.

Neither engines nor accessories can be modified. By this we mean any shape, content or function changes which may differ from what previously conceived. Furthermore this includes any addition and /or removal of material.

All dimensional measures in the technical drawings are in mm.

TOUTES LES PARTS DU MOTEUR DOIVENT ETRE ORIGINALES VORTEX ROK.

Ni le moteurs ni les accessoires peuvent être modifiés. Tout changement dans la forme, le contenu ou le fonctionnement qui puisse apporter des modifications au projet initial est interdit. Ci-inclus aussi l'addition et/ou l'enlèvement de matériaux.

Toutes les mesures dimensionnelles dans les dessins techniques sont en mm.

VALVOLA PARZIALIZZATRICE PNEUMATICA MOD. 2015 CON DOPPIA MOLLA DI COMPRESSIONE
PNEUMATIC POWER VALVE MOD. 2015 WITH DOUBLE COMPRESSION SPRING
VALVE DE PUISSANCE PNEUMATIQUE MOD. 2015 AVEC DOUBLE RESSORT COMPRESSION

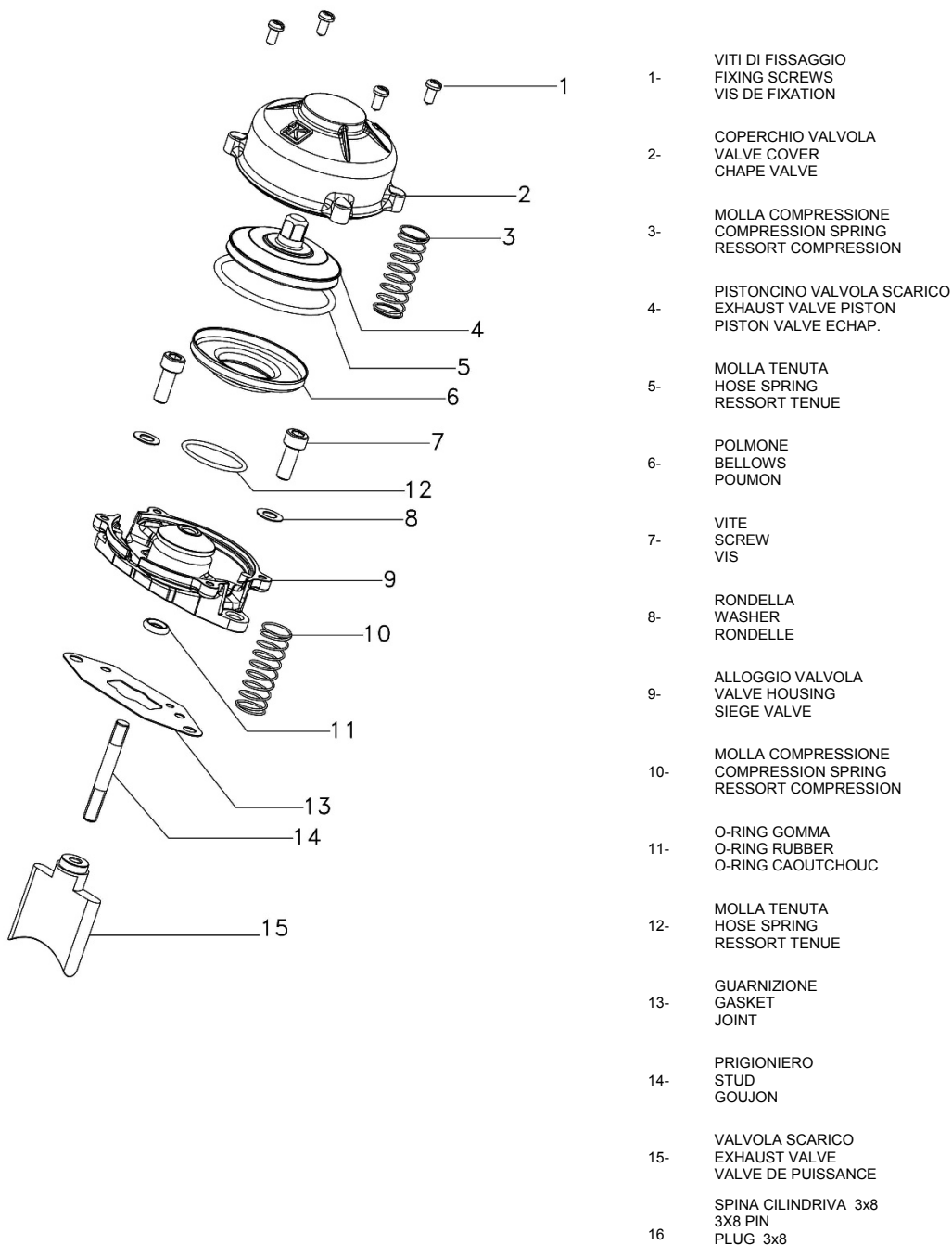

ATTENTION

TUTTI LE PARTI DEL MOTORE DEVONO ESSERE ORIGINALI VORTEX ROK.

Né il motore né gli accessori possono essere in alcun modo modificati.

Per modifica si intende qualsiasi cambiamento di forma, contenuto o funzione, che rappresenti una condizione di differenza da quanto originariamente costruito, ivi inclusa l'aggiunta e/o l'asportazione di materiale

Tutte le misure dimensionali nei disegni tecnici si intendono in mm.

ALL THE ENGINE PARTS MUST BE ORIGINAL BY VORTEX ROK.

Neither engines nor accessories can be modified. By this we mean any shape, content or function changes which may differ from what previously conceived. Furthermore this includes any addition and /or removal of material.

All dimensional measures in the technical drawings are in mm.

TOUTES LES PARTS DU MOTEUR DOIVENT ETRE ORIGINALES VORTEX ROK.

Ni le moteurs ni les accessoires peuvent être modifiés. Tout changement dans la forme, le contenu ou le fonctionnement qui puisse apporter des modifications au projet initial est interdit. Ci-inclus aussi l'addition et/ou l'enlèvement de matériaux.

Toutes les mesures dimensionnelles dans les dessins techniques sont en mm.

MARMITTA, SILENZIATORE E COMPONENTI
EXHAUST MUFFLER, SILENCER AND COMPONENTS
POT D'ÉCHAPEMENT, SILENCIEUX ET SES ÉLÉMENTS

PESO WEIGHT POIDS
2057 gr. min

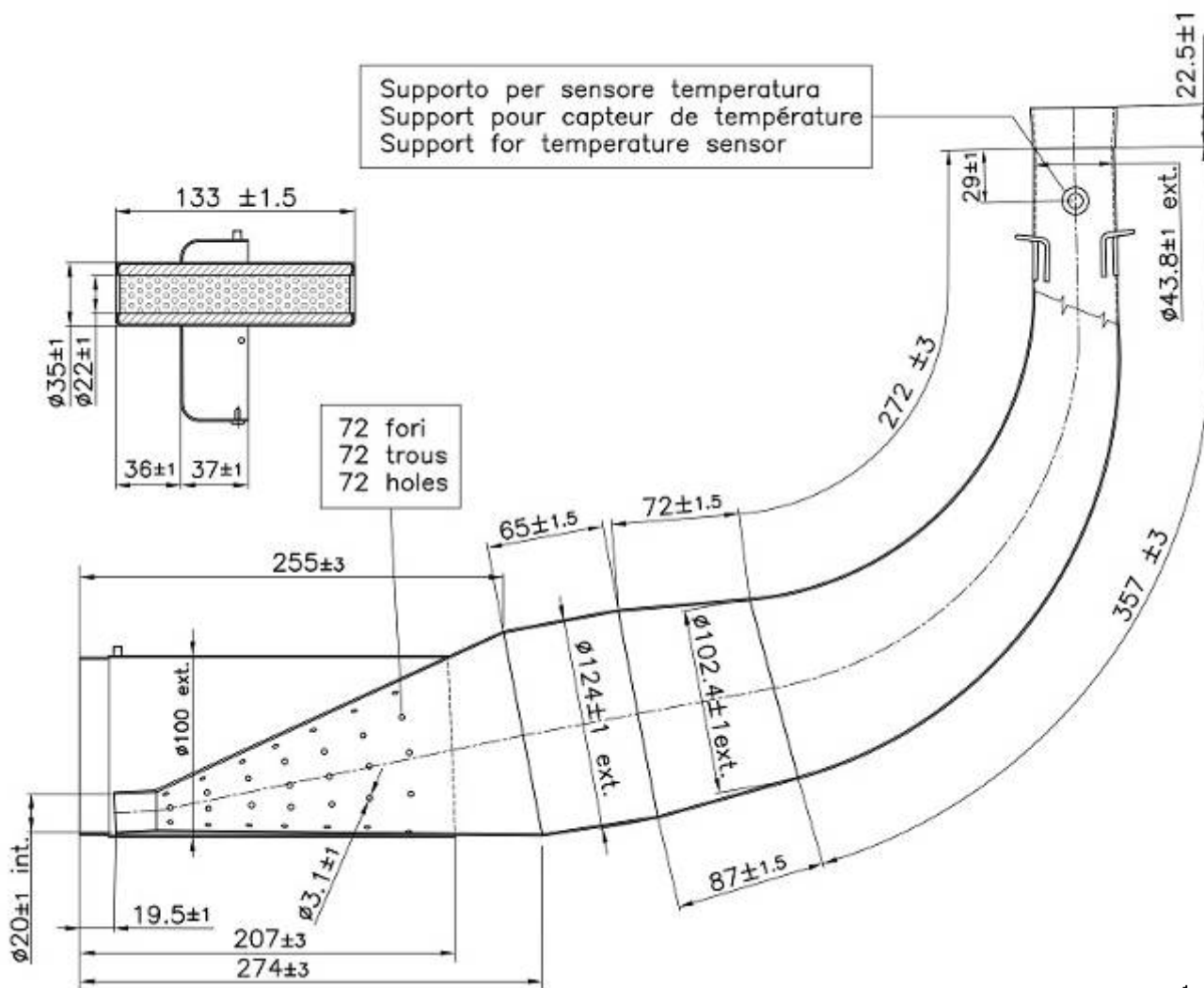

ATTENTION

TUTTI LE PARTI DEL MOTORE DEVONO ESSERE ORIGINALI VORTEX ROK.

Né il motore né gli accessori possono essere in alcun modo modificati.

Per modifica si intende qualsiasi cambiamento di forma, contenuto o funzione, che rappresenti una condizione di differenza da quanto originariamente costruito, ivi inclusa l'aggiunta e/o l'asportazione di materiale

Tutte le misure dimensionali nei disegni tecnici si intendono in mm.

ALL THE ENGINE PARTS MUST BE ORIGINAL BY VORTEX ROK.

Neither engines nor accessories can be modified. By this we mean any shape, content or function changes which may differ from what previously conceived. Furthermore this includes any addition and /or removal of material.

All dimensional measures in the technical drawings are in mm.

TOUTES LES PARTS DU MOTEUR DOIVENT ÊTRE ORIGINALES VORTEX ROK.

Ni le moteurs ni les accessoires peuvent être modifiés. Tout changement dans la forme, le contenu ou le fonctionnement qui puisse apporter des modifications au projet initial est interdit. Ci-inclus aussi l'addition et/ou l'enlèvement de matériaux.

Toutes les mesures dimensionnelles dans les dessins techniques sont en mm.

IMPORTANTE-IMPORTANT-IMPORTANT

SULLA MARMITTA DEVE ESSERE PRESENTE IN SEDE DI VERIFICA IL LOGO DI RICONOSCIMENTO, DVS, SAMPATO DIRETTAMENTE DALLA DITTA PRODUTTRICE.

DURING EXAMINATION, ON THE EXHAUST IT MUST BE INDICATED THE IDENTIFICATION LOGO DVS, IMPRINTED DIRECTLY BY THE MANUFACTURER.

PENDANT LA VERIFICATION, SUR LE POT D'ÉCHAPPEMENT, IL DOIT ÊTRE PRÉSENT LE LOGO DE RECONNAISSANCE DVS, IMPRIMÉ DIRECTEMENT DE LA MAISON PRODUCTRICE.



ATTENTION

TUTTI LE PARTI DEL MOTORE DEVONO ESSERE ORIGINALI VORTEX ROK.

Né il motore né gli accessori possono essere in alcun modo modificati.

Per modifica si intende qualsiasi cambiamento di forma, contenuto o funzione, che rappresenti una condizione di differenza da quanto originariamente costruito, ivi inclusa l'aggiunta e/o l'asportazione di materiale

Tutte le misure dimensionali nei disegni tecnici si intendono in mm.

ALL THE ENGINE PARTS MUST BE ORIGINAL BY VORTEX ROK.

Neither engines nor accessories can be modified. By this we mean any shape, content or function changes which may differ from what previously conceived. Furthermore this includes any addition and /or removal of material.

All dimensional measures in the technical drawings are in mm.

TOUTES LES PARTS DU MOTEUR DOIVENT ÊTRE ORIGINALES VORTEX ROK.

Ni le moteurs ni les accessoires peuvent être modifiés. Tout changement dans la forme, le contenu ou le fonctionnement qui puisse apporter des modifications au projet initial est interdit. Ci-inclus aussi l'addition et/ou l'enlèvement de matériaux.

Toutes les mesures dimensionnelles dans les dessins techniques sont en mm.

CARBURATORE E COMPONENTI IBEA ROK DVS 2 JET
CARBURETTOR AND COMPONENTS IBEA ROK DVS 2 JET
IBEA ROK DVS 2 JET CARBURATEUR ET SES ELEMENTS



ELENCO PARTI DI RICAMBIO – SPARE PARTS

351 – Guarnizione del diaframma Diaphragm gasket	360 – Guarnizione coperchio filtro Fuel strainer cover gasket	370 – Fulcro leva controllo apertura Inlet control lever fulcrum	403 – Molla per comando Spring for shaft
352 – Diaframma Diaphragm	361 – Coperchio filtro carburante Fuel strainer cover	371 – Vite leva di controllo apertura Inlet control lever screw	404 – Clip comando Shaft clip
353 – Copertura diaframma Diaphragm cover	362 – Vite coperchio filtro Fuel strainer cover screw	372 – Spillo di aspirazione Inlet needle	406 – Supporto cavo gas Support for cable
355 – Guarnizione pompa benzina Fuel pump gasket	363 – Vite miscela del minimo Idle mixture screw L.	373 – Molla di tensione aspirazione Inlet tension spring	407 – Dado speciale M6 Special nut M6
356 – Diaframma pompa benzina Fuel pump diaphragm	364 – Molla vite miscela del minimo Idle mixture screw spring	374 – Vite miscela alti regimi H High speed mixture screw H	408 – Kit membrane Kit membrane
357 – Corpo pompa benzina Fuel pump body	365 – Rondella vite miscela Idle mixture screw washer	400 – Vite farfalla Screw for butterfly	409 – Kit completo Complete kit
358 – Vite pompa benzina Fuel pump screw	366 – Packing miscela del minimo Idle mixture screw packing	401 – otturatore Shutter	
359 – Filtro del carburante Fuel strainer screen	369 – Leva controllo apertura Inlet control lever	402/1-Comando otturatore Special shaft whit shutter	



LE REGOLAZIONI DEL CARBURATORE SONO CONSENTITE PURCHE' SI UTILIZZINO SOLO PARTI ORIGINALI IBEA ROK DVS
 THE CARBURETTOR ADJUSTMENTS ARE ALLOWED ONLY EMPLOYING ORIGINAL IBEA ROK DVS PARTS
 LE REGLAGES DU CARBURATEUR SONT ADMIS A CONDITION QU'ON UTILISE SEULEMENT DES PARTIES ORIGINELLES IBEA ROK DVS

ATTENTION

TUTTI LE PARTI DEL MOTORE DEVONO ESSERE ORIGINALI VORTEX ROK.

Né il motore né gli accessori possono essere in alcun modo modificati.

Per modifica si intende qualsiasi cambiamento di forma, contenuto o funzione, che rappresenti una condizione di differenza da quanto originariamente costruito, ivi inclusa l'aggiunta e/o l'asportazione di materiale

Tutte le misure dimensionali nei disegni tecnici si intendono in mm.

ALL THE ENGINE PARTS MUST BE ORIGINAL BY VORTEX ROK.

Neither engines nor accessories can be modified. By this we mean any shape, content or function changes which may differ from what previously conceived. Furthermore this includes any addition and /or removal of material.

All dimensional measures in the technical drawings are in mm.

TOUTES LES PARTS DU MOTEUR DOIVENT ETRE ORIGINALES VORTEX ROK.

Ni le moteurs ni les accessoires peuvent être modifiés. Tout changement dans la forme, le contenu ou le fonctionnement qui puisse apporter des modifications au projet initial est interdit. Ci-inclus aussi l'addition et/ou l'enlèvement de matériaux.

Toutes les mesures dimensionnelles dans les dessins techniques sont en mm.

CARBURATORE IBEA ROK DVS 2 JET
 CARBURETTOR IBEA ROK DVS 2 JET
 IBEA ROK DVS 2 JET CARBURATEUR



DIMA CONTROLLO CARBURATORE
 CARBURETTOR CHEKING TEMPLATE
 GABARIT POUR LA VERIFICATION DU PROFIL
 DU CARBURATEUR



ATTENTION

TUTTI LE PARTI DEL MOTORE DEVONO ESSERE ORIGINALI VORTEX ROK.

Né il motore né gli accessori possono essere in alcun modo modificati.
 Per modifica si intende qualsiasi cambiamento di forma, contenuto o funzione, che rappresenti una condizione di differenza da quanto originariamente costruito, ivi inclusa l'aggiunta e/o l'asportazione di materiale
 Tutte le misure dimensionali nei disegni tecnici si intendono in mm.

ALL THE ENGINE PARTS MUST BE ORIGINAL BY VORTEX ROK.

Neither engines nor accessories can be modified. By this we mean any shape, content or function changes which may differ from what previously conceived. Furthermore this includes any addition and /or removal of material.
 All dimensional measures in the technical drawings are in mm.

TOUTES LES PARTS DU MOTEUR DOIVENT ETRE ORIGINALES VORTEX ROK.

Ni le moteurs ni les accessoires peuvent être modifiés. Tout changement dans la forme, le contenu ou le fonctionnement qui puisse apporter des modifications au projet initial est interdit. Ci-inclus aussi l'addition et/ou l'enlèvement de matériaux.
 Toutes les mesures dimensionnelles dans les dessins techniques sont en mm.

**FILTRO D'ASPIRAZIONE
INLET SILENCER
SILENCIEUX D'ASPIRATION**

MODELLO, TIPO,
MODEL TYPE
MODELE, TYPE

ARROW, E

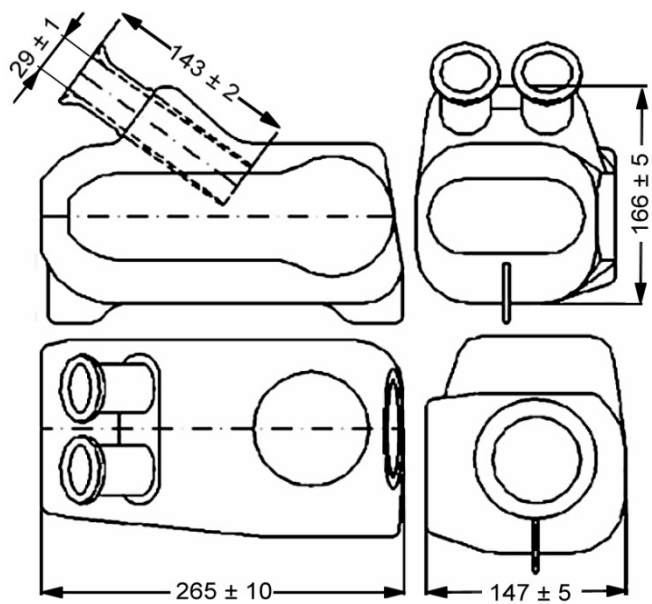

ACI SPORT
Via Solferino 32 - 00187 Roma (RM)

ATTENTION

TUTTI LE PARTI DEL MOTORE DEVONO ESSERE ORIGINALI VORTEX ROK.

Né il motore né gli accessori possono essere in alcun modo modificati.

Per modifica si intende qualsiasi cambiamento di forma, contenuto o funzione, che rappresenti una condizione di differenza da quanto originariamente costruito, ivi inclusa l'aggiunta e/o l'asportazione di materiale

Tutte le misure dimensionali nei disegni tecnici si intendono in mm.

ALL THE ENGINE PARTS MUST BE ORIGINAL BY VORTEX ROK.

Neither engines nor accessories can be modified. By this we mean any shape, content or function changes which may differ from what previously conceived. Furthermore this includes any addition and /or removal of material.

All dimensional measures in the technical drawings are in mm.

TOUTES LES PARTS DU MOTEUR DOIVENT ETRE ORIGINALES VORTEX ROK.

Ni le moteurs ni les accessoires peuvent être modifiés. Tout changement dans la forme, le contenu ou le fonctionnement qui puisse apporter des modifications au projet initial est interdit. Ci-inclus aussi l'addition et/ou l'enlèvement de matériaux.

Toutes les mesures dimensionnelles dans les dessins techniques sont en mm.

BALANCER SHAFT PHASING.

IN THE PIC BELOW, WE SHOW YOU IN DETAILS THE ORIGINAL POSITION (TO BE RESPECTED) OF THE BALANCER SHAFT PHASING IN THE DVS ENGINE.

AS THE TIMING SHOULD BE REGULAR THE NOTCHS OF THE GEARS AND THE BALANCER SHAFT SHOULD CORRESPOND WHEN THE PISTON IS AT THE DEAD UPPER POINT. AS SHOWED ON THE DRAWING.

FASATURA DELL'ALBERO DI BILANCIAMENTO

NELLA FOTO RIPIORTATA SOTTO, VI MOSTRIAMO IN DETTAGLIO LA POSIZIONE ORIGINALE (CHE DEVE ESSERE RISPETTATA) DELLA FASATURA DELL'ALBERO DI BILANCIAMENTO DEL MOTORE DVS.

AFFINCHÉ LA FASATURA SIA REGOLARE LE TACCHE DEGLI INGRANAGGI E DEL CONTRALBERO DEVONO CORRISPONDERE QUANDO IL PISTONE SI TROVA AL PUNTO MORTO SUPERIORE, COME INDICATO NEL DISEGNO.



SCHEDA D'IDENTIFICAZIONE

IDENTIFICATION SHEET

FICHE D'ID

ATTENTION

TUTTI LE PARTI DEL MOTORE DEVONO ESSERE ORIGINALI VORTEX ROK.

Né il motore né gli accessori possono essere in alcun modo modificati.

Per modifica si intende qualsiasi cambiamento di forma, contenuto o funzione, che rappresenti una condizione di differenza da quanto originariamente costruito, ivi inclusa l'aggiunta e/o l'asportazione di materiale

Tutte le misure dimensionali nei disegni tecnici si intendono in mm.

ALL THE ENGINE PARTS MUST BE ORIGINAL BY VORTEX ROK.

Neither engines nor accessories can be modified. By this we mean any shape, content or function changes which may differ from what previously conceived. Furthermore this includes any addition and /or removal of material.

All dimensional measures in the technical drawings are in mm.

TOUTES LES PARTS DU MOTEUR DOIVENT ETRE ORIGINALES VORTEX ROK.

Ni le moteurs ni les accessoires peuvent être modifiés. Tout changement dans la forme, le contenu ou le fonctionnement qui puisse apporter des modifications au projet initial est interdit. Ci-inclus aussi l'addition et/ou l'enlèvement de matériaux.

Toutes les mesures dimensionnelles dans les dessins techniques sont en mm.

ACCENSIONE PVL
PVL IGNITION
ALLUMAGE PVL



COME DA ART. 2, PAR. 16.7 DEL REGOLAMENTO TECNICO CIK/FIA, A DISCREZIONE DEI COMMISSARI TECNICI E' AMMESSO SCAMBIARE I SISTEMI DI ACCENSIONE DEI CONCORRENTI CON SISTEMI FORNITI DAGLI ORGANIZZATORI (DELLO STESSO MODELLO OMOLOGATO)

AS PER ART. 2, PAR. 16.7 OF THE CIK/FIA TECHNICAL REGULATIONS, ON DECISION OF THE STEWARDS, IT WILL BE AUTHORISED TO INTERCHANGE ENTRANTS' IGNITION SYSTEMS FOR THE SYSTEMS SUPPLIED BY THE ORGANISERS (SAME HOMOLOGATED MODELS)

COMME DU ART. 2, PAR. 16.7 DU REGLEMENT TECHNIQUE CIK/FIA, SUR DECISION DES COMMISSAIRES SPORTIFS, IL SERA POSSIBLE D'INTERCHANGER L'ALLUMAGE DES CONCURRENTS CONTRE CELUI FOURNI PAR LES ORGANISATEURS (MEMES MODELES HOMOLOGUES).

E' CONSENTITO SOLO L'UTILIZZO DI CENTRALINE, BOBINE E STATORI MARCHIATE OTK, COME BEN VISIBILE NELLE FIGURE SOPRA RIPORTATE.

USE OF CDI BOX AND IGNITION MARKED OTK WILL BE ALLOWED, AS MENTIONED IN THE ABOVE PICTURES.

IL SERA PERMIS L'UTILISATION DES MODULE CDI ET DE L'ALLUMAGE MARQUES OTK, COMME BIEN VISIBILE DANS LES ILLUSTRATION CI-DESSUS REPORTEES



ATTENTION

TUTTI LE PARTI DEL MOTORE DEVONO ESSERE ORIGINALI VORTEX ROK.

Né il motore né gli accessori possono essere in alcun modo modificati.

Per modifica si intende qualsiasi cambiamento di forma, contenuto o funzione, che rappresenti una condizione di differenza da quanto originariamente costruito, ivi inclusa l'aggiunta e/o l'asportazione di materiale

Tutte le misure dimensionali nei disegni tecnici si intendono in mm.

ALL THE ENGINE PARTS MUST BE ORIGINAL BY VORTEX ROK.

Neither engines nor accessories can be modified. By this we mean any shape, content or function changes which may differ from what previously conceived. Furthermore this includes any addition and /or removal of material.

All dimensional measures in the technical drawings are in mm.

TOUTES LES PARTS DU MOTEUR DOIVENT ETRE ORIGINALES VORTEX ROK.

Ni le moteurs ni les accessoires peuvent être modifiés. Tout changement dans la forme, le contenu ou le fonctionnement qui puisse apporter des modifications au projet initial est interdit. Ci-inclus aussi l'addition et/ou l'enlèvement de matériaux.

Toutes les mesures dimensionnelles dans les dessins techniques sont en mm.